

How to measure your products correctly

what you need to know

How to measure your products correctly

Accurate product data is an essential component of a visible, secure, and sustainable supply chain – yet research has shown that 80 per cent of professionals have little idea how to measure the products they sell. In this fully illustrated guide, we take you through the steps you need to take to ensure your products are measured properly and consistently in a standardised way.

This handbook is an abridged version of the full [GS1 GDS Package Measurement Standard](#), which focuses on grocery products. Please refer to this for more detailed information that might not be covered in this guide.

Introduction

Without a consistent way to measure products, it is obvious that there will be discrepancies from company to company.

After all, how would trading partners know that they had both identified the same depth for an item? How would a retailer and a brand know if they are even using the same system to measure a product?

It is for this reason that GS1 created their package measurement rules as a guide for all trading partners wishing to exchange data about product package measurements. They provide a common procedure for all and are intended to ensure global compatibility.

How to use this handbook

If you want to know about consumer trade items (products on retail shelves), start at [page 2](#).

If you are looking for non-consumer trade items (all others), please refer to [page 13](#).

This handbook is an abridged version of the full GS1 GDS Package Measurement Standard, which focuses on grocery products.

To use this book to work out your item's measurements you will learn how to:

- Know whether your item is a consumer or non-consumer item
- Determine the Default Front or Natural Base, as appropriate
- Verify which dimensions are the height, width and depth
- Apply the appropriate measuring method for the type of item

Consumer (point of sale) trade items

The following rules apply to consumer trade items, i.e. those that are meant to pass through point of sale.



If a consumer trade item is also traded as a logistics trade item, it still needs to be viewed as a consumer trade item and measured accordingly.

Determining the Default Front of an item

Prior to any measurement capture, the Default Front of the trade item must be determined. The Default Front is the surface with the largest area that is used by the manufacturer to “sell” the product to the consumer.

In other words, it is the surface with markings such as the product name, and consumer declarations such as the net content.



The determination of Default Front is intended to provide a consistent, repeatable process to identify measurements for a given product package and may not always represent the “as merchandised” or shelf orientation of the product.



The following illustrates the problem when not using standards – as the product can be merchandised either lying flat or standing up vertically, height could mean different things to each retailer.

When determining the Default Front, standard text elements such as consumer declarations should be viewed horizontally, as product branding and/or graphics may not be consistent with a horizontal or vertical orientation.

If there are two alike surfaces that could be the Default Front – one containing standard text elements such as consumer declarations and the other without – the Default Front will be the surface containing text elements such as net content.

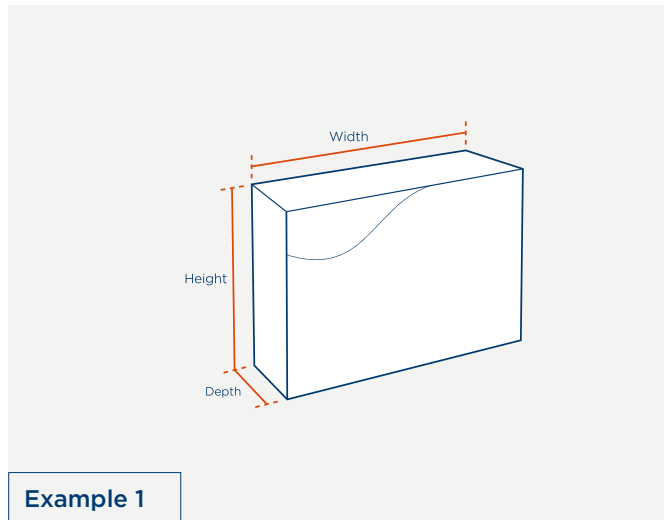

Example 1

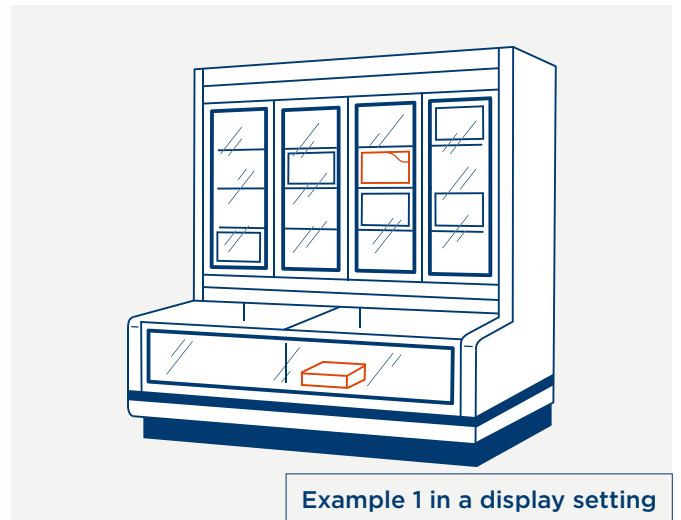

Example 1 in a display setting

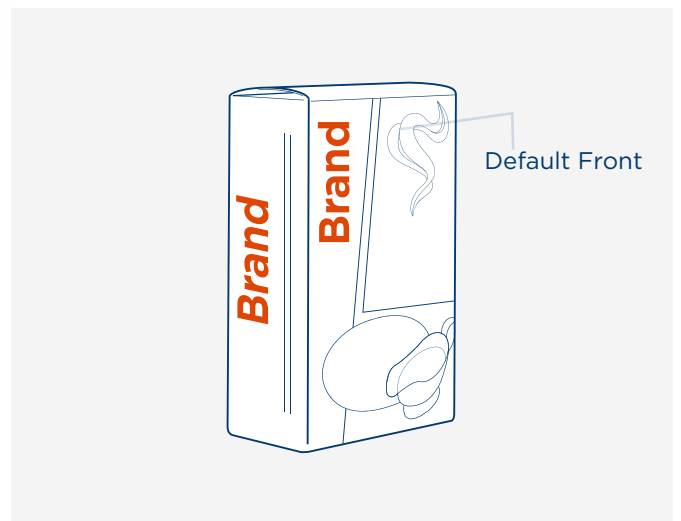
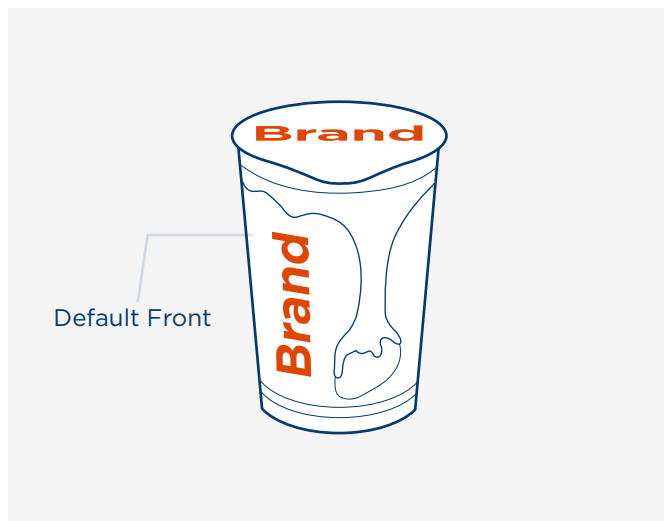

Some product packages have more than one possible front with the same surface area. These products can be presented both vertically and horizontally on the shelves. If a product package has more than one possible front, the highest side is the Default Front

Determining the height, width and depth

After the Default Front has been determined, it is possible to determine the height, width and depth of an item. While facing the Default Front:

- Height: from the base to the top
- Width: from the left to the right
- Depth: from the front to the back

After the height, width and depth have been determined, the dimensions can be measured. Always measure the maximum distance, i.e. include things such as caps, lids and complimentary products in the measurement.

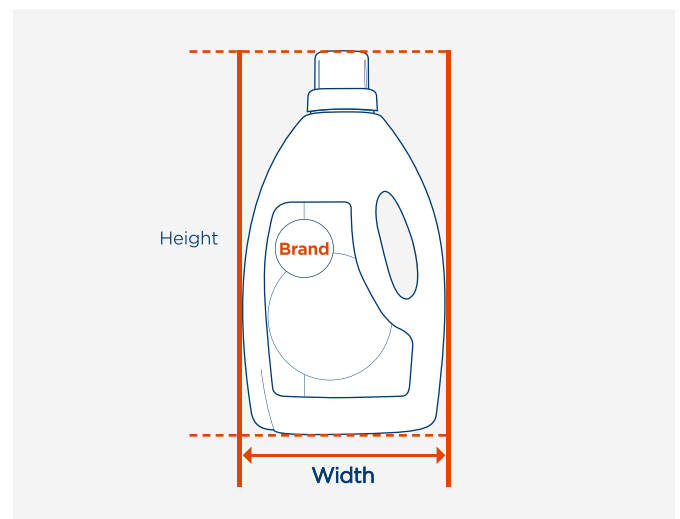
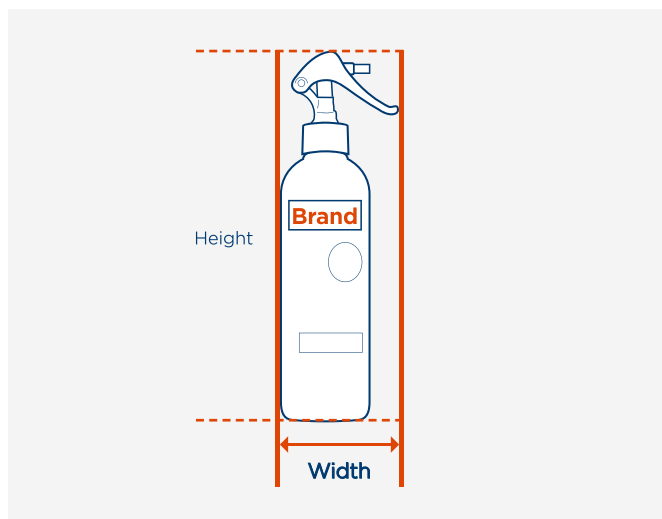
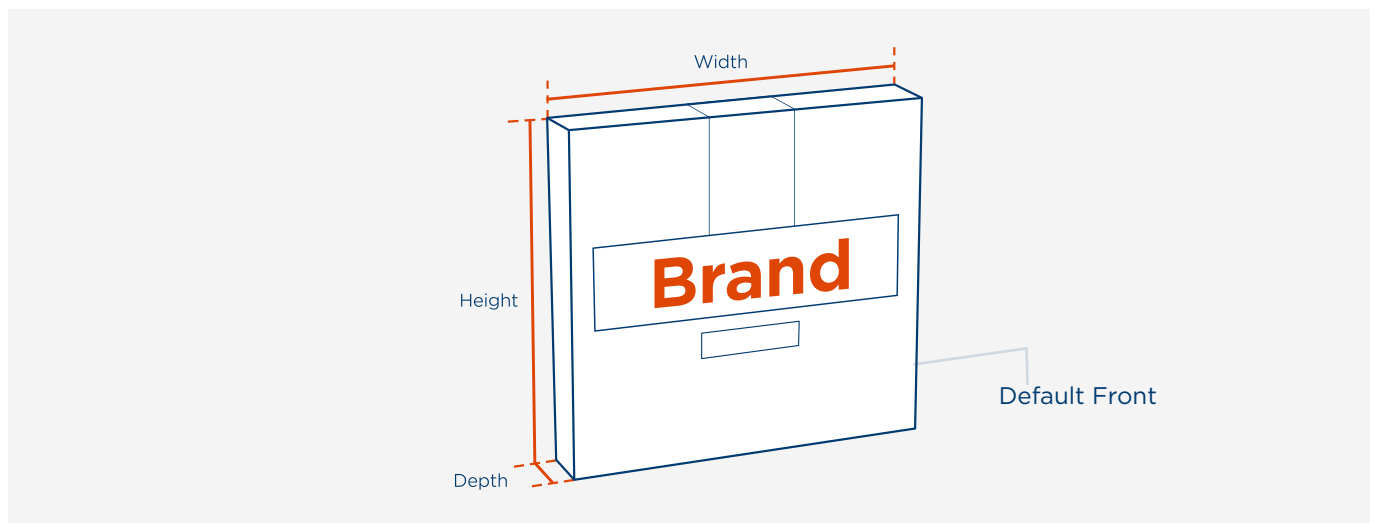

Measuring different types of packaging

Boxes and cartons

The dimensions for this type of packaging should be straightforward to work out once you have determined the Default Front, as detailed in the previous section.

Measurements are made facing the Default Front while the trade item is on a flat surface, such as a table.

- Height is from the bottom-most point to the topmost point
- Width is from the left-most point to the right-most point
- Depth is from the Default Front to the farthest opposite
- The Default Front is the surface with the largest area that is used by the manufacturer to “sell” the product to the consumer.

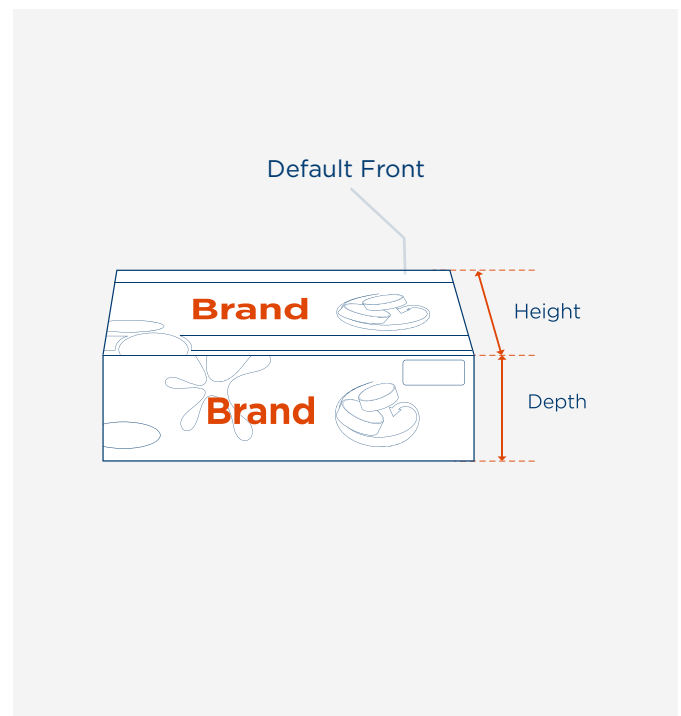
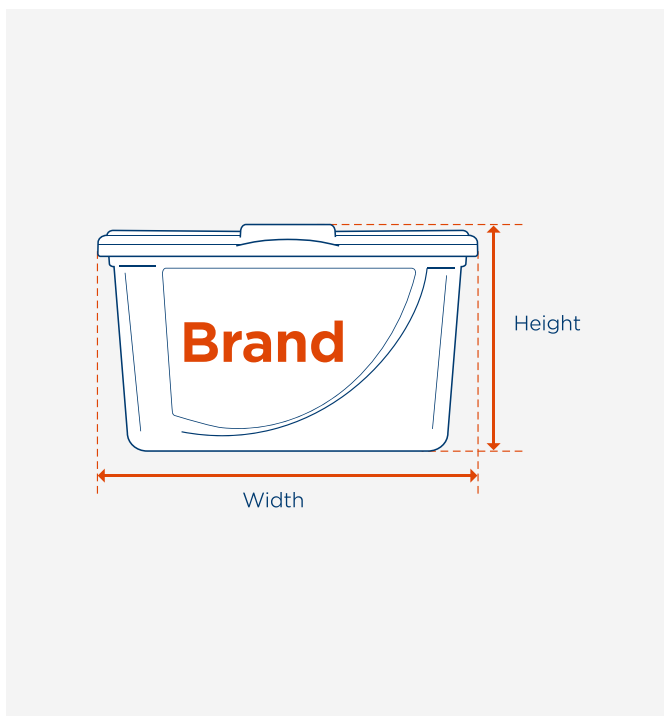

Flexible packaging

Flexible packaging is defined as any package or part of a package the shape of which can be readily changed. Flexible packaging includes things like bags and pouches.

Consumer trade items in flexible packaging should be measured lying flat with the contents settled unless a specific exception is noted in the following sections.

Flexible packaging – formed, filled, and sealed without gussets

Consumer trade items which are formed, filled and sealed without gussets – triangular seams or sealing pattern for bags or pouches used to create corners – will be measured edge to edge including the sealed seams, with the item lying flat after evenly settling the contents.

The measurements are taken while facing the trade item's Default Front, and after having pulled out and then released the seams. This rule applies to packaging whose contents are loose and granular, such as bagged loose sweets, chips, rice, etc.

- Height is from the bottom-most point to the top-most point
- Width is from the left-most point to the right-most point
- Depth is from the Default Front to the farthest opposite surface

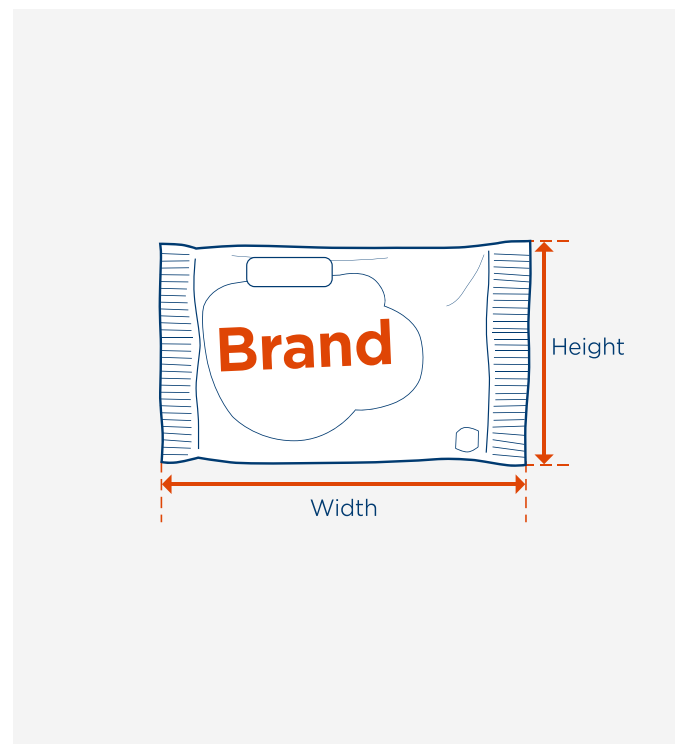

Stand up pouches

This section describes Stand-up pouches where the seal or seam is intended to serve as a base, which allows the item to stand up on its end. These trade items will be measured while standing upright on a flat surface facing the Default Front from edge to edge, including:

- Height is from the bottom-most point to the top-most point
- Width is from the left-most point to the right-most point
- Depth is from the Default Front to the farthest opposite surface

Examples of this type of trade item include pouches of nuts, beverages and snacks.

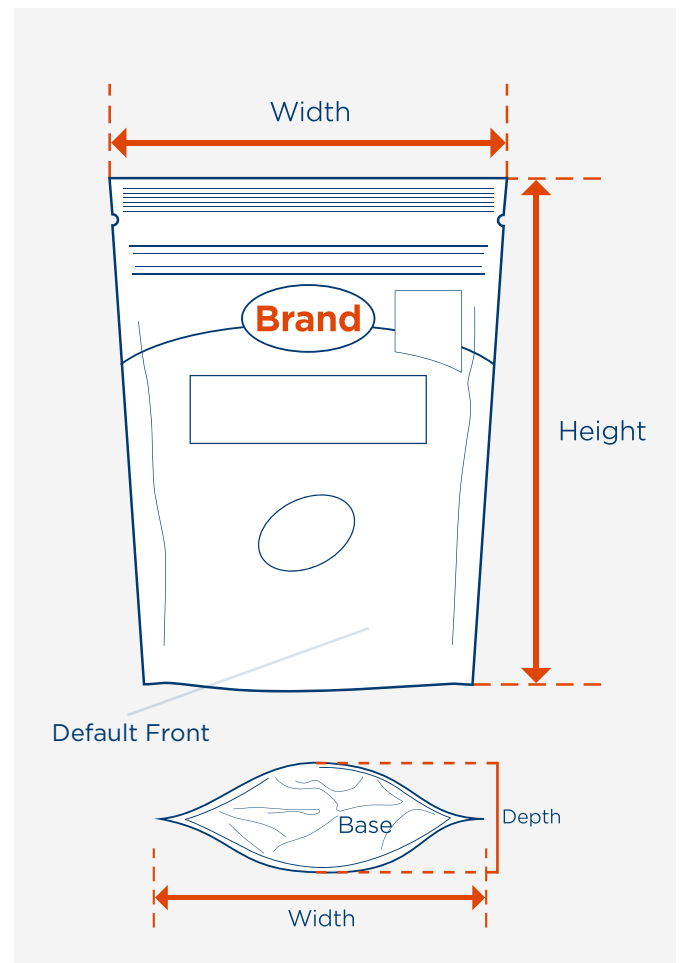

Product or internal packaging that defines the size and or shape of the package

This section describes trade items where the contents of the trade item’s flexible package contain product or internal packaging that uniformly defines the size and/or shape of the package.

This can occur, for example, when the packaging material is less stiff than its contents. The trade item will be measured by folding the excess flexible material (if any) to the product and then measuring the trade item and then measuring the trade item, for example bread bags.

Measurements are made facing the Default Front while the trade item is on a flat surface, such as a table, oriented in such a way that allows the product or internal packaging to sit naturally.

- Height is from the bottom-most point to the top-most point
- Width is from the left-most point to the right-most point
- Depth is from the Default Front to the farthest opposite surface

Examples of this type of trade item include chocolate bars and bread.

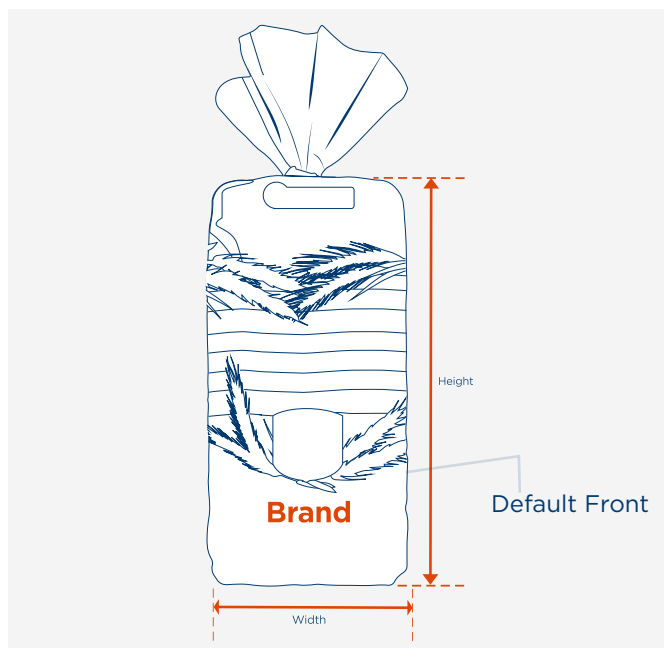
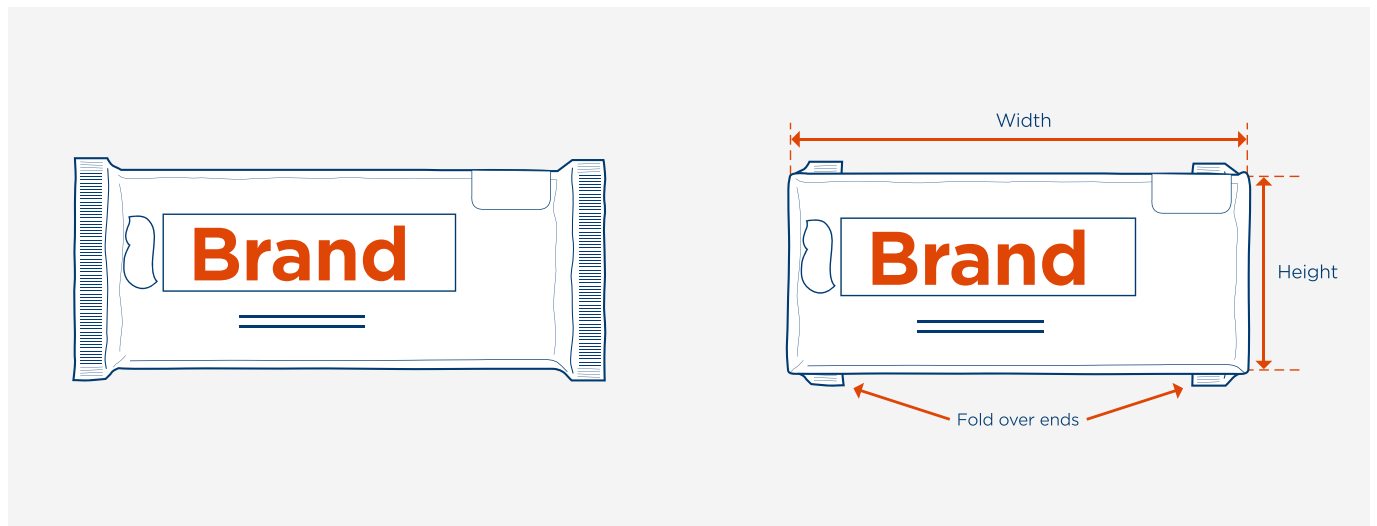

Gusseted bags

This section describes trade items which are gusseted bags. The gussets – triangular seams or sealing pattern for bags or pouches used to create corners – may be on one or more ends of the trade item. This could be either sides and/or a bottom gusset which are designed to provide a base. (See [example on page 7](#))

These trade items are measured standing with the intended base on a flat surface such as a table, while facing the Default Front.

- Height is from the bottom-most point to the top-most point
- Width is from the left-most point to the right-most point
- Depth is from the Default Front to the farthest opposite surface

i The height of the trade item will be measured with package head-space extended, with the only exception being if the material is not rigid enough to stand by itself on the package base or if the flap is folded over. This rule applies only to gusseted bags.

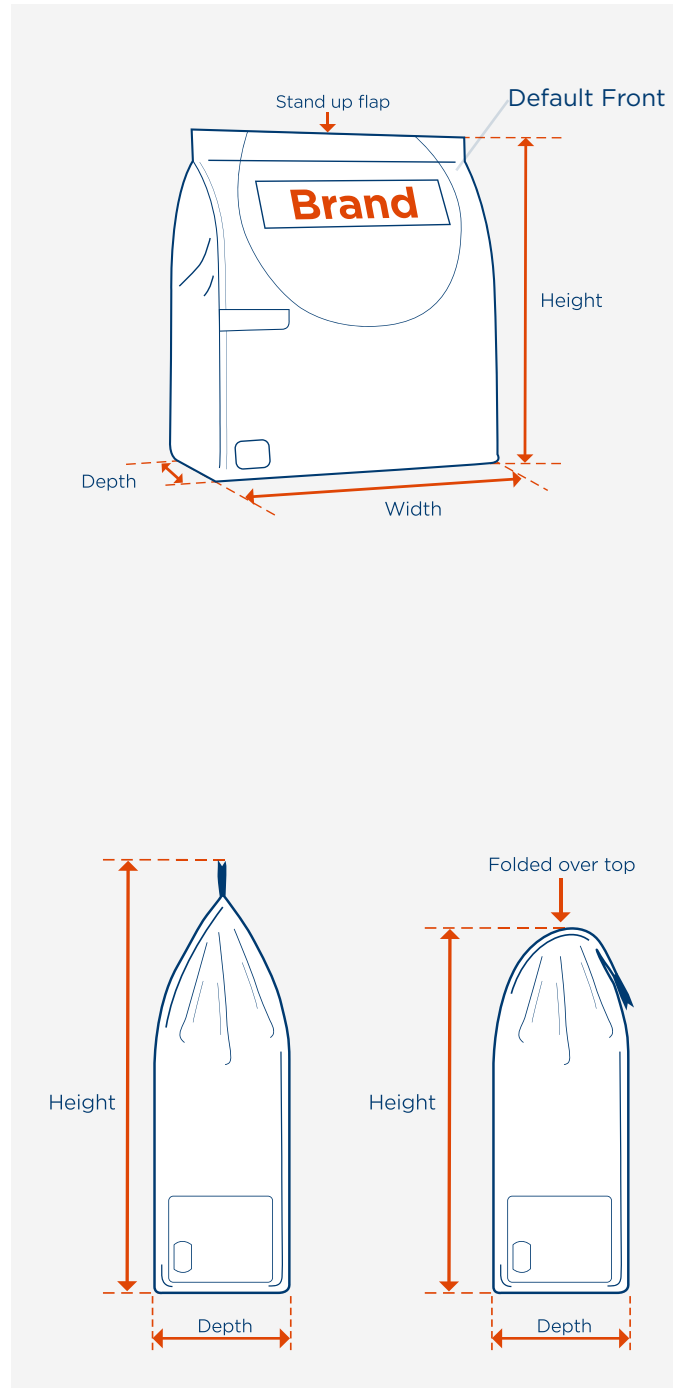

Cylindrical items

For cylindrical items, two dimensions will be nominally equal. The Default Front will determine which of the dimensions are equal. See examples below.

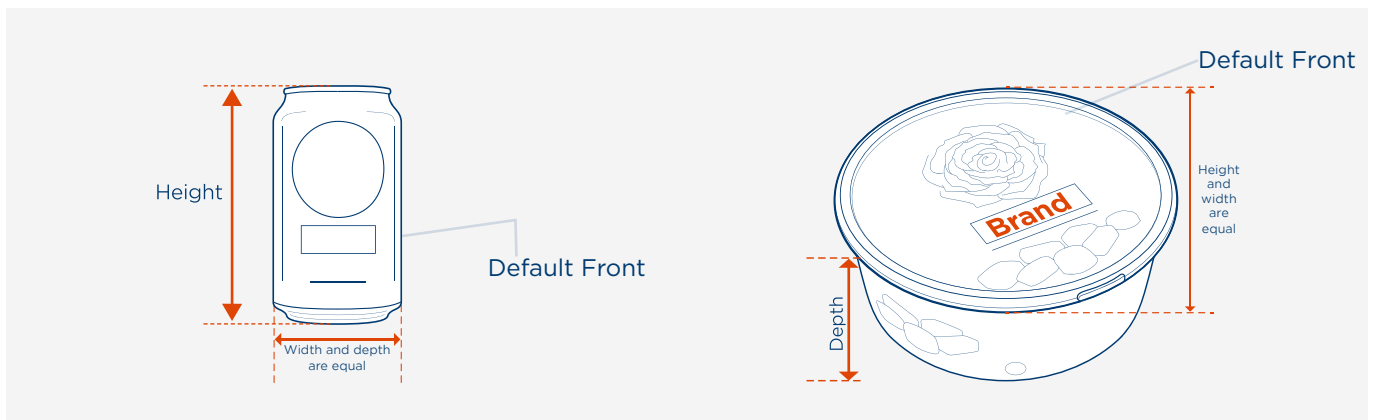

Stand-up packaging with leaning or irregular verticals

This section applies to items which have a rigid or semi-rigid packaging that drive a specific shape for the product which includes a base on which the product can stand and be displayed in a natural position.

The edges that rise vertically from the base, however, are not vertical and may lean inwards to form a pyramidal or conical shape for the product. These consumer trade items will be measured while standing naturally on their base (upright on a flat surface facing the Default Front).



The Default Front may not be perfectly vertical as it may be located on the leaning face of the product. Height will then be the measurement from the flat surface to the topmost point, width is from the leftmost point to the rightmost point and Depth is from the Default Front to the farthest opposite surface.

Examples of this type of consumer trade item include ready-to-eat sandwiches and confectionary items.

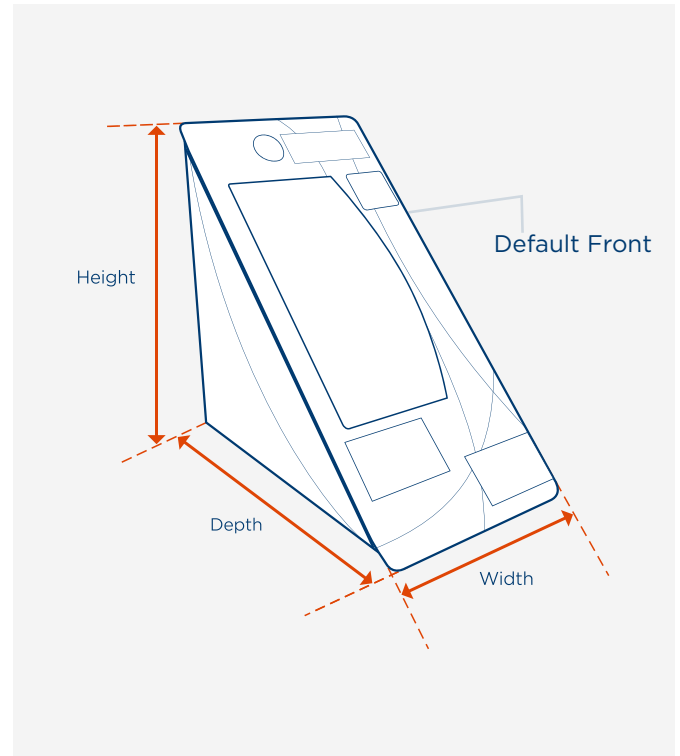

Hanging items

A hanging item is a trade item that is presented on a hanger or contains a hole for hanging purposes. Two measurement methods exist for hanging items based on the packaging type.

Hanging items in rigid packaging

Measure the trade item while facing the Default Front as if it were hanging. Measure the maximum distance, including the hanger tab.

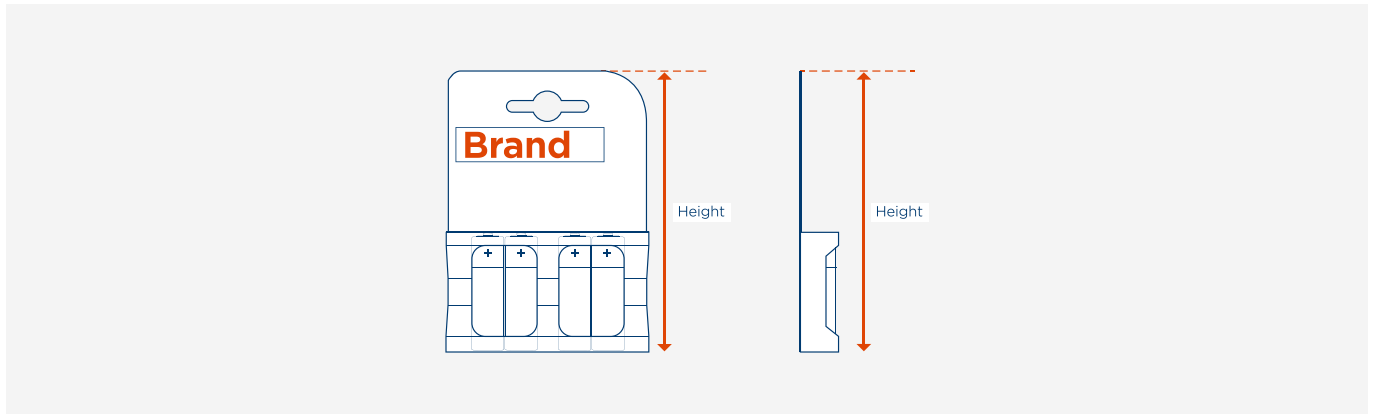

Hanging items in flexible packaging

The rule regarding hanger holes does not apply to flexible packaging. For specific guidance regarding the measurement rules for flexible packaging, please see the [previous section](#) on flexible packaging rules.

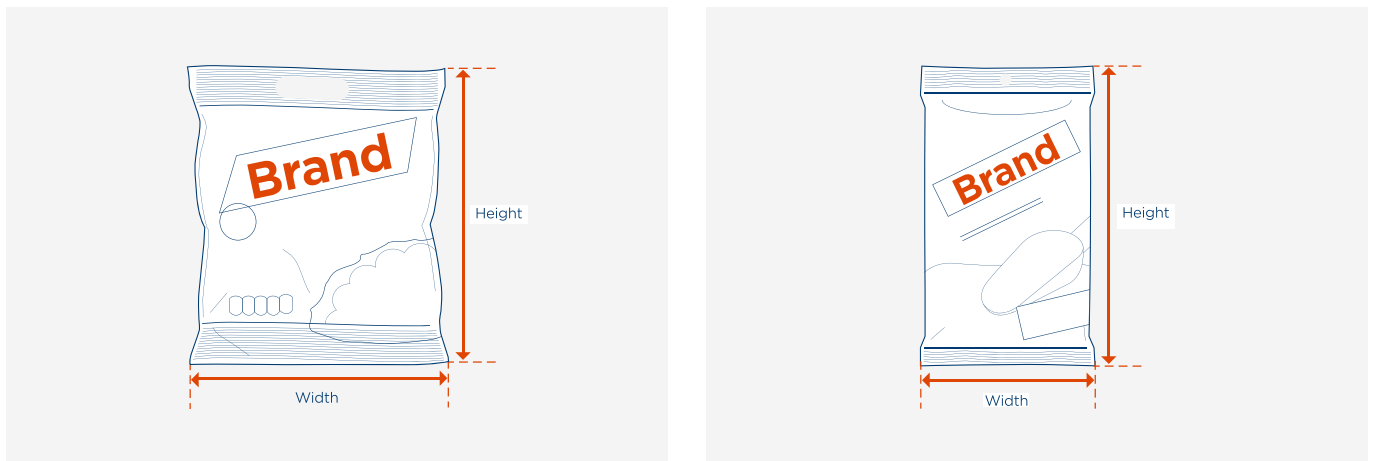

The hole or hanging orientation is not used to determine the Default Front.

Multi-packs

Multi-packs are consumer trade items in themselves but contain a multiple of single items that may or may not be sold individually to the consumer. When a trade item meets the definition of a multi-pack it will be measured according to the Default Front rule for that complete consumer trade item.

As demonstrated in the illustrations to the right, product graphics may significantly impact the determination of the Default Front and the resulting measurements.

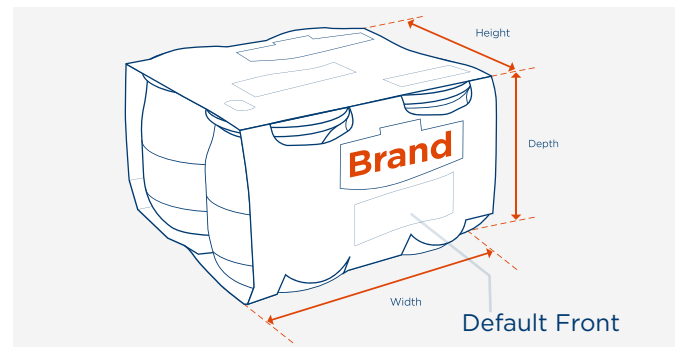
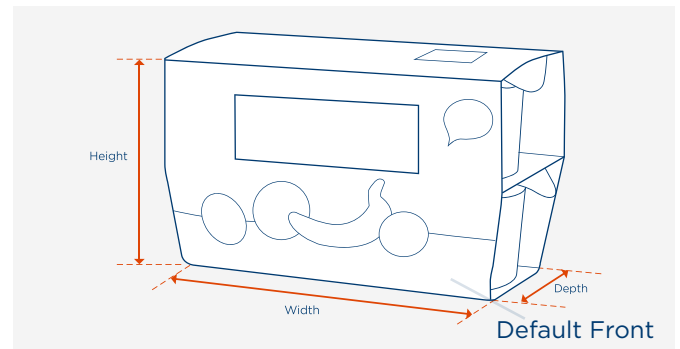

Non-consumer trade items

Non-consumer trade items are identified with a GTIN and are intended for supply chain scanning, such as at distribution centres, warehouses and back of store. Trade items include cases up to the largest form of bulk packaging for trade items and may include pallets.



The orientation of how a non-consumer trade item is shipped should not be used to determine its dimensions.

Determining the Natural Base

The Natural Base of the non-consumer trade item must be identified before the height, width and depth of the non-consumer trade item can be determined.

The Natural Base is the natural underside of the packaged item.

If markings are present that indicate the correct package orientation, those markings should be used to identify the natural base.

Some examples of markings include (in order of prioritisation):

- Arrows
- Directional words such as “top” or “bottom”
- Consistent text orientation on one or more sides
- Barcode(s) printed on the package, which are parallel to the surface (natural base) on which it sits.

If no orientation markings exist, the largest, flat surface upon which the package naturally rests shall be considered the natural base.

If a clearly intended opening is present, that side should be considered the top of the package. This does not include perforations.

Non-consumer trade items where the package or part of a package’s shape can be readily changed (e.g., flexible packaging) should be measured lying flat with the contents settled.

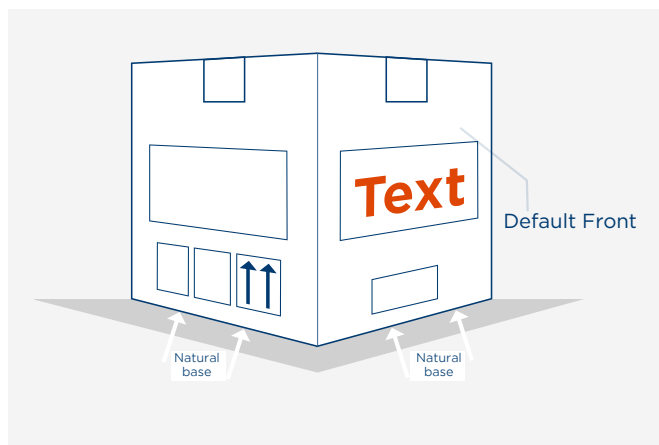

Determining the height, width and depth of a non-consumer trade item

After it has been established which side is the natural base, the height, width and depth of the non-consumer trade item can be determined.

- **Height:** the distance between the natural base of the non-consumer trade item and the top.
- **Width:** the shorter side of the natural base of the non-consumer trade item.
- **Depth/Length:** the longer side of the natural base of the non-consumer trade item.

Make sure to capture any protrusions on the packaging which may extend the measurements (e.g., handles). When measuring a trade item the maximum measurement should be recorded for any given dimension.

In the case of a square base there is no shortest or longest side. Width and depth are then identical.



If the position of a logo or product mark does not indicate top or bottom orientation, it is not used to determine Natural Base.

Display boxes

The Natural Base rule is used to measure display boxes. This rule is independent of whether the display box has an open top or a tear-away top.

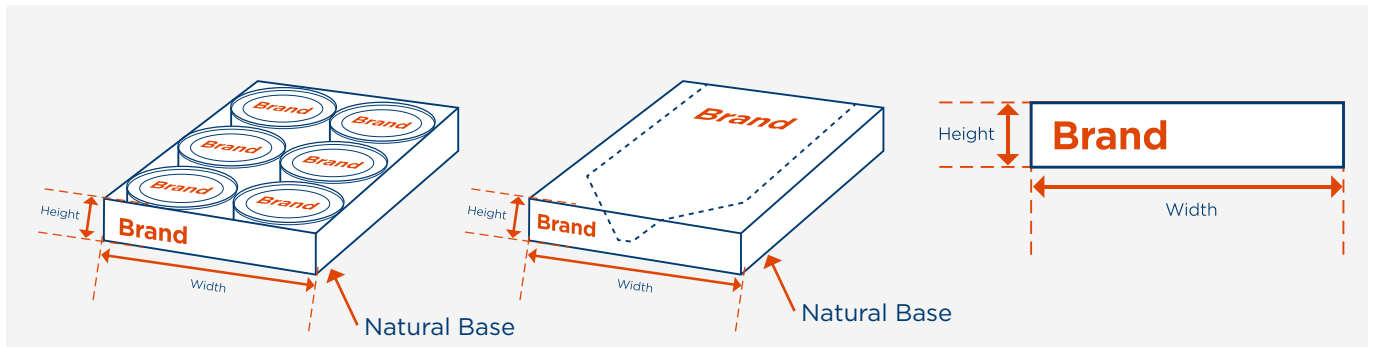

Floor-ready displays

Floor and counter displays may be shipped unassembled. The shipping container for the unassembled display is measured as any other non-consumer trade item using the Natural Base rule.

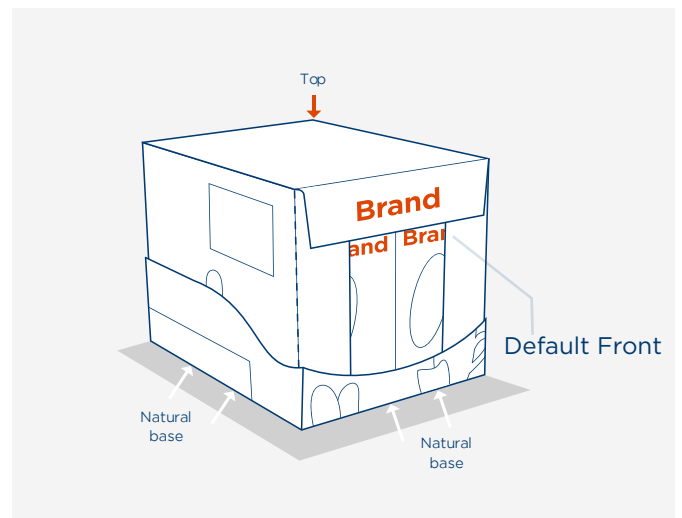
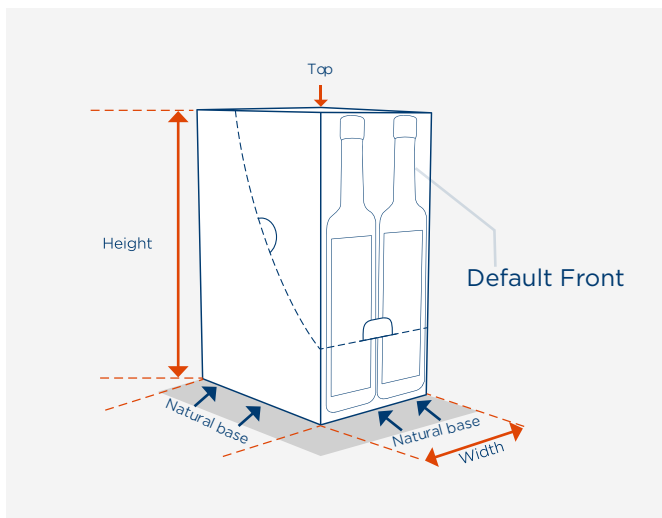

Hang sells (clip strips)

Hang sells (clip strips) are hanging, display items that carry multiples of consumer trade items, and are identified with a GTIN.

They are an exception when it comes to applying the packaging rules. The strips are measured as hanging using the rules for consumer trade items even if the clip strip is not marked for crossing point of sale.

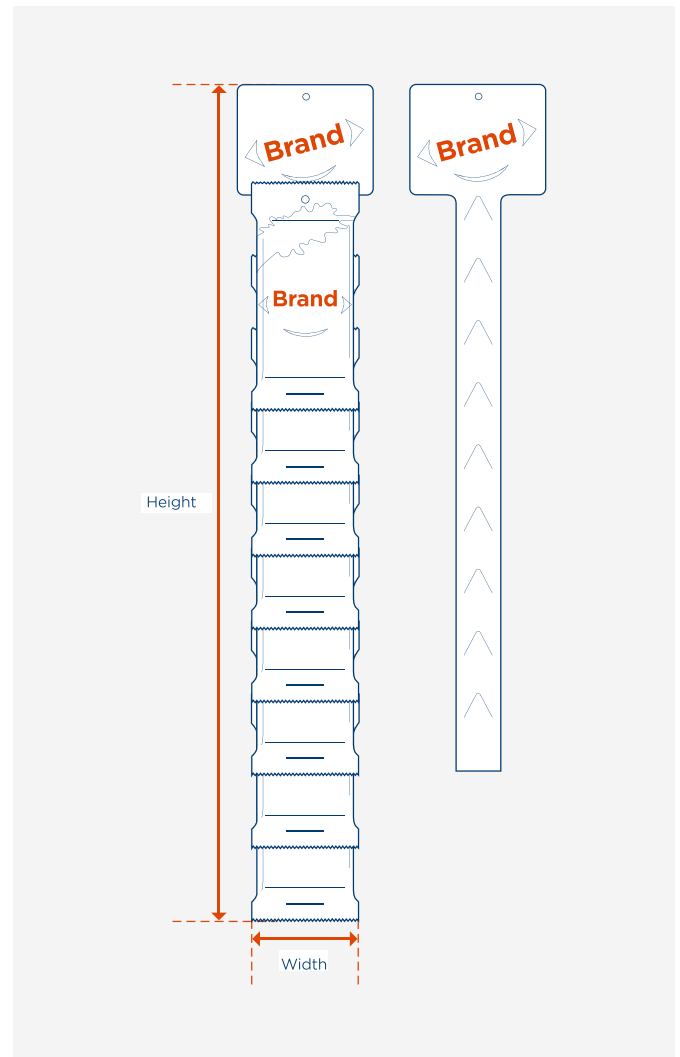

We hope you found this useful

If you think that your business would benefit from additional support, GS1 New Zealand training might be of interest. Our public and in-company courses are both interactive and practical.

Regardless of the industry you work in, whether your company is large or small, and whatever your current level of understanding of GS1 standards, our training will help you effortlessly adopt our standards.

Contact support@gs1nz.org to discuss your requirements. Further information can also be found at gs1.org/standards/gs1-package-measurement-rules-standard/current-standard



Level 2, Woolstore Professional Centre
158 The Terrace, Wellington 6011

0800 10 23 56
support@gs1nz.org
gs1nz.org